PTA ANKERSCHIENEN-SYSTEM UND ZUBEHÖR PTA ANCHOR CHANNEL SYSTEM AND ACCESSORIES	3 – 45
PTU TRAPEZBLECHBEFESTIGUNGSSCHIENEN PTU CAST-IN CHANNELS	46 – 54
TRANSPORTANKER-SYSTEM FÜR RINGKUPPLUNG LIFTING SYSTEM FOR RING CLUTCH	54 – 65
KUGELKOPF-TRANSPORTANKER-SYSTEM SPHERICAL HEAD ANCHOR SYSTEM	66 – 77
HÜLSENANKER-SYSTEM SOCKET ANCHOR SYSTEM	78 – 88
DOPPELWAND-SYSTEM DOUBLE WALL SYSTEM	89 – 96
SANDWICHPLATTEN-VERANKERUNGEN SANDWICH PANEL SYSTEM	97 – 110
KAP-STAHL-WELLE KAP-STEEL-WAVE	111 – 119
ZERTIFIKATE CERTIFICATES	120 – 122
ALLGEMEINE GESCHÄFTSBEDINGUNGEN TERMS OF BUSINESS	123 – 125

TRANSPORTANKER-SYSTEM FÜR RINGKUPPLUNG

LIFTING SYSTEM FOR RING CLUTCH

Spreizanker Spread anchor

Laststufe
Loadstep
0,7 t - 22,0 t



Zweilochanker Two hole anchor

Laststufe
Loadstep
0,7 t - 22,0 t



Aufstellanker einseitig Erection anchor one-sided

Laststufe
Loadstep
1,4 t - 22,0 t



Aufstellanker beidseitig Erection anchor both-sided

Laststufe
Loadstep
1,4 t - 22,0 t



Flachfußanker Flat foot anchor

Laststufe
Loadstep
0,7 t - 22,0 t



Plattenanker Plate anchor

Laststufe
Loadstep
1,4 t - 10,0 t



Universalanker Universal anchor

Laststufe
Loadstep
1,25 t



Ringkupplung Ring clutch

Laststufe
Loadstep
0,7 t - 26,0 t



Aussparungskörper Gummi Recess former Rubber

Laststufe
Loadstep
0,7 t - 22,0 t



Aussparungskörper Bajonett Recess former Bayonet

Laststufe
Loadstep
0,7 t - 22,0 t



Halteplatte Holding plate

Laststufe
Loadstep
0,7 t - 22,0 t

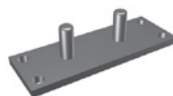

Halteschraube Holding screw

Laststufe
Loadstep
0,7 t - 22,0 t



TRANSPORTANKER-SYSTEM FÜR RINGKUPPLUNG

LIFTING SYSTEM FOR RING CLUTCH

Spreizanker Spread anchor

Anwendungsgebiet:
Wandelemente, Träger,
Stützen, Binder

Application:
Wall units, Columns,
Beams, Trusses



Artikel-Nr. Article No.	Laststufe [t] Loadstep [t]	Länge [mm] Length [mm]
6300-01,4-120	1,4	120
6300-01,4-150	1,4	150
6300-02,0-140	2,0	140
6300-02,0-200	2,0	200
6300-02,0-250	2,0	250
6300-02,5-120	2,5	120
6300-02,5-150	2,5	150
6300-02,5-200	2,5	200
6300-02,5-250	2,5	250
6300-03,0-160	3,0	160
6300-03,0-200	3,0	200
6300-03,0-250	3,0	250
6300-04,0-180	4,0	180
6300-04,0-240	4,0	240
6300-05,0-190	5,0	190
6300-05,0-230	5,0	230
6300-05,0-400	5,0	400
6300-07,5-250	7,5	250
6300-07,5-300	7,5	300
6300-07,5-400	7,5	400
6300-10,0-340	10,0	340
6300-17,0-380	17,0	380
6300-22,0-500	22,0	500
6300-22,0-620	22,0	620

Zweilochanker Two hole anchor

Anwendungsgebiet:
Dünnwandige Betonelemente

Application:
Thin concrete units



6000-01,4-090	1,4	90
6000-02,0-090	2,0	90
6000-02,5-090	2,5	90
6000-03,0-120	3,0	120
6000-04,0-120	4,0	120
6000-05,0-120	5,0	120
6000-07,5-160	7,5	160
6000-10,0-160	10,0	160
6000-12,5-240	14,0	240
6000-17,0-240	17,0	240
6000-22,0-300	22,0	300

Aufstellanker einseitig Erection anchor one-sided

Anwendungsgebiet:
Dünne Betonelemente, die vertikal
aufgestellt werden müssen

Application:
Thin wall units, which have to be
lifted in a vertical position



6700-01,4-200	1,4	200
6700-02,5-230	2,5	230
6700-04,0-270	4,0	270
6700-05,0-300	5,0	300
6700-07,5-320	7,5	320
6700-10,0-400	10,0	400
6700-12,5-500	12,5	500
6700-17,0-500	17,0	500
6700-22,0-500	22,0	500

Aufstellanker beidseitig Erection anchor both-sided

Anwendungsgebiet:
Dünne Betonelemente, die vertikal
aufgestellt werden müssen

Application:
Thin wall units, which have to be
lifted in a vertical position



6750-01,4-200	1,4	200
6750-02,5-230	2,5	230
6750-04,0-270	4,0	270
6750-05,0-300	5,0	300
6750-07,5-320	7,5	320
6750-10,0-400	10,0	400
6750-12,5-500	12,5	500
6750-17,0-500	17,0	500
6750-22,0-500	22,0	500

TRANSPORTANKER-SYSTEM FÜR RINGKUPPLUNG LIFTING SYSTEM FOR RING CLUTCH

	Artikel-Nr. Article No.	Laststufe [t] Loadstep [t]	Länge [mm] Length [mm]	Fuß [mm] Foot [mm]
Flachfußanker Flat foot anchor Anwendungsgebiet: Deckenelemente, Rohre Application: Ceiling slabs, Tubes	6800-01,4-075	1,40	70	100
	6800-02,0-085	2,00	85	100
	6800-02,5-090	2,50	90	100
	6800-03,0-100	3,00	100	120
	6800-04,0-120	4,00	120	120
	6800-05,0-130	5,00	130	120
	6800-05,3-140	5,30	140	120
	6800-07,5-160	7,50	160	120
	6800-10,0-185	10,00	185	120
	6800-12,5-200	12,50	200	200
	6800-17,0-280	17,00	280	200
6800-22,0-300	22,00	300	200	



			Platte Plate
Plattenanker Plate anchor Anwendungsgebiet: Dünne Deckenelemente Application: Thin ceiling slabs	6200-01,4-055	2,50	80/08
	6200-02,5-080	2,50	80/08
	6200-05,0-120	5,00	100/10
	6200-10,0-160	10,00	140/12

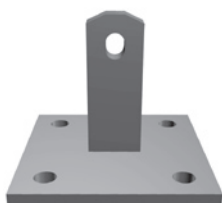

	6100-01,25-120	1,25	120
--	----------------	------	-----

Universalanker Universal anchor

Anwendungsgebiet:
Vereint alle Vorteile

Application:
Unites all advantages



Ringkupplung mit Bügel zum manuellen Lösen Ring clutch with shackle for manual release

Anwendungsgebiet:
Verwendbar für alle Ankertypen

Application:
Suitable for all anchor types



	Lastgruppe [t] Loadgroup [t]
6400-02,50	0,70 - 2,50
6400-05,00	3,00 - 5,00
6400-10,00	7,50 - 10,00
6400-26,00	12,50 - 26,00

CE geprüft | CE tested

6405-02,50	0,70 - 2,50
6405-05,00	3,00 - 5,00
6405-10,00	7,50 - 10,00
6405-26,00	12,50 - 26,00

Ringkupplung mit Seil Ring clutch with rope

6401-1,25	0,70 - 1,25
6401-02,5	1,40 - 2,50
6401-05,0	3,00 - 5,00
6401-10,0	7,50 - 10,00
6401-26,0	12,50 - 26,00

TRANSPORTANKER-SYSTEM FÜR RINGKUPPLUNG

LIFTING SYSTEM FOR RING CLUTCH

Aussparungskörper Gummi

Recess former Rubber

Anwendungsgebiet:
Für alle Ankertypen außer
Universalanker

Application:
For all anchor types except
Universal anchor



Artikel-Nr. Article No.	Lastgruppe [t] Loadgroup [t]
----------------------------	---------------------------------

6600-02,5	0,7 - 2,5
6600-05,0	3,0 - 5,0
6600-10,0	7,5 - 10,0
6600-26,0	12,5 - 26,0

Aussparungskörper Bajonett

Recess former Bayonet

Anwendungsgebiet:
Für alle Ankertypen außer
Universalanker

Application:
For all anchor types except
Universal anchor



6500-02,5	0,7 - 2,5
6500-05,0	3,0 - 5,0
6500-10,0	7,5 - 10,0
6500-26,0	12,5 - 26,0

Halteplatte

Holding plate

Anwendungsgebiet:
Für Aussparungskörper, zur
Befestigung an der Schalung

Application:
For Recess former, for
fastening onto the formwork

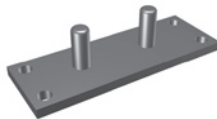

6550-02,5	0,7 - 2,5
6550-05,0	3,0 - 5,0
6550-10,0	7,5 - 10,0
6550-26,0	12,5 - 26,0

Halteschraube

Holding screw

Anwendungsgebiet:
Für Aussparungskörper

Application:
For Recess former



		Gewinde Thread
6560-08	0,7 - 5,0	M 8
6560-12	7,5 - 10,0	M 12
6560-16	12,5 - 26,0	M 16

TRANSPORTANKER-SYSTEM FÜR RINGKUPPLUNG

LIFTING SYSTEM FOR RING CLUTCH

Die Wahl und Positionierung des richtigen Ankers ist sehr wichtig und die folgenden Punkte müssen berücksichtigt werden.

- Gewicht des Fertigteils
- Anzahl der Anker
- Anordnung der Anker
- Haftung an der Schalung
- Spreizwinkel bei Gehängen
- Schrägzugeigenschaften des Abhebers/Ankers
- Betonfestigkeit beim ersten Abheben
- Dynamische Kräfte

The selection and positioning of lifting anchors is very important and the following points have to be taken into consideration.

- Weight of the unit
- Number of anchors
- Positioning of the anchors
- Adhesion to the mould
- Spread or splay angle factors
- Sling type and arrangement
- Concrete strength at first lift
- Dynamic loads

Das Transportanker-System hat einen 3-fachen Sicherheitsfaktor gegen Stahlbruch und eine 2,5-fache Sicherheit gegen Betonbruch. Die Ringkupplung hat Sicherheitsfaktor 5.

Alle Sicherheitsfaktoren und Transportkriterien basieren auf einer Betondruckfestigkeit von 15 N/mm² beim Entschalen und 25 N/mm² beim Transportieren und Aufstellen.

The lifting system has a minimum safety factor of 3 against steel fracture. A safety factor of 2.5 is used against concrete fracture. The lifting shackle has a safety factor of 5.

All safety factors and lifting criteria are based on the concrete strength of 15 N/mm² at demoulding and 25 N/mm² at transporting and erecting.

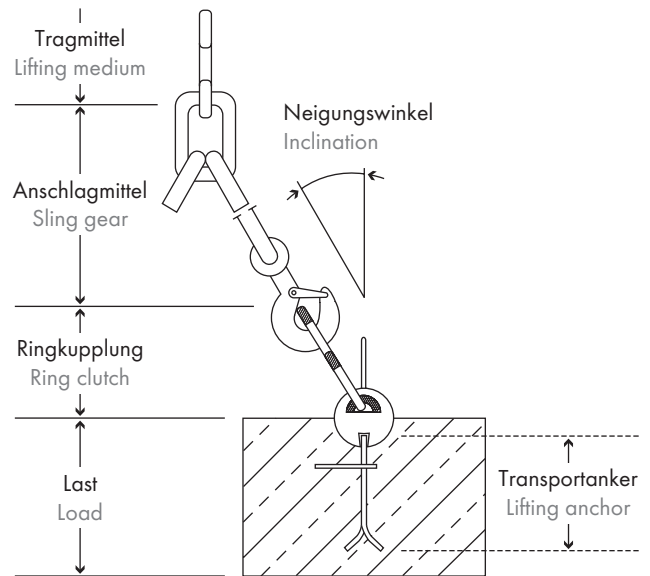

Folgende Kriterien sollten Sie bei der Wahl des richtigen Verankerungs-Systems mit einbeziehen:

The following criteria should be taken into consideration before selecting the correct lifting system:

Gewicht des Fertigteils

Weight of the unit

Bei der Ermittlung des Gewichts frischer Stahlbetonfertigteile ist ein spezifisches Gewicht von 25 N/mm³ zugrunde zu legen.

As a rule, a figure of 25 N/mm³ is used for calculating the dead weight of a freshly reinforced concrete unit.

Anzahl der Anker

Number of anchors

Die Anzahl der Anker ist abhängig von dem verwendeten Gehänge. Bitte entnehmen Sie die Lastverteilung der Anker den statischen Systemen.

Falls dies nicht möglich ist, muß jedes auftretende Gewicht individuell für jeden Anker berechnet werden.

The following criteria should be taken into consideration before selecting the correct lifting system:

The number of anchors depends on the used lifting sling. Please check for the load distribution on the anchors in the static system.

If this is not possible then the loads on each individual anchor must be calculated.

TRANSPORTANKER-SYSTEM FÜR RINGKUPPLUNG

LIFTING SYSTEM FOR RING CLUTCH

Anordnung der Anker

Positioning of the anchors

Transportanker sollten möglichst symmetrisch zum Schwerpunkt des Fertigteils angeordnet werden. Dies, in Verbindung mit der richtigen Wahl des Gehänges, wird eine gleichmäßige Belastung der Anker sicherstellen.

It is advisable that the lifting anchors are placed symmetrically to the centre of gravity. This, combined with the correct sling arrangement, will ensure even load on the anchors.

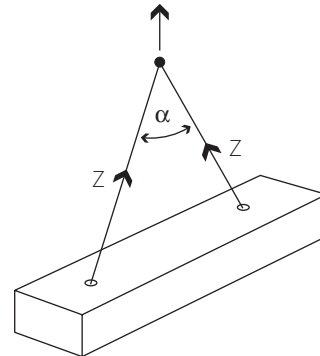

Haftung an der Schalung

Adhesion of the mould

Die Haftung an der Schalung ist unter anderem von der Beschaffenheit der Schalungsoberfläche abhängig.

- Glatte, geölte Schalung 1 kN/m²
- Glatte, nicht geölte Schalung 2 kN/m²
- Rauhe Schalung 3 kN/m²

The adhesion inside the mould depends on the structure of the mould surface.

- Smooth oiled mould 1 kN/m²
- Smooth non-oiled mould 2 kN/m²
- Rough mould 3 kN/m²

Winkel α Angle α	Spreizwinkelfaktor Spread angle factor
0°	1,00
30°	1,04
60°	1,16
90°	1,41

Spreizwinkel bei Gehängen

Spread or splay angle factors

Falls ein Gehänge verwendet wird, das ein Kräftedreieck bildet, erhöhen sich, im Gegensatz zum einfachen Schrägzug, die an den Ankern angreifenden Kräfte (Seillasten).

If the used lifting sling forms a triangle, the forces on the anchors increase in relation to the included angle of the sling.

Dynamische Kräfte

Dynamic loads

Die auf den Transportanker einwirkenden Kräfte sind unter Berücksichtigung des Stoßfaktors zu errechnen.

The weight of the unit should be multiplied by the impact factor given in the following table.

	Stationärer Kran, Drehkran, Schienenkran Tower, Rail mounted crane	Transport in ebenen Gelände Travelling on smooth ground	Transport in unebenem Gelände Travelling on rough ground
Hubgeschwindigkeit Lifting speed	< 90 m/min	≥ 90 m/min	
Stoßfaktor Impact factor	1.00	≥ 1.30	≥ 2.00

TRANSPORTANKER-SYSTEM FÜR RINGKUPPLUNG

LIFTING SYSTEM FOR RING CLUTCH

Bei statisch unbestimmten Gehängen müssen die Anker so bemessen werden, daß zwei Ankerpunkte die gesamte Last aufnehmen können.

When 4-legged slings are being used only two legs are bearing elements or carrying the load.

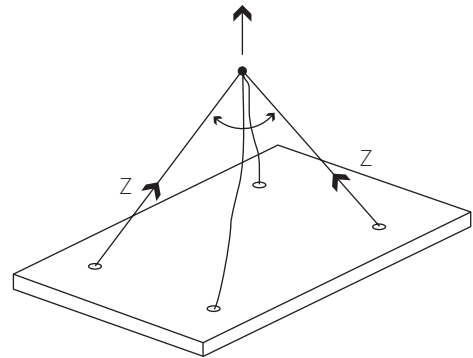

Bei einem 4-Strang-Gehänge mit Ausgleichswippe wird die Lastverteilung auf vier Anker gewährleistet.

Through a compensating rig system you will assure to distribute the load evenly to all four anchors.

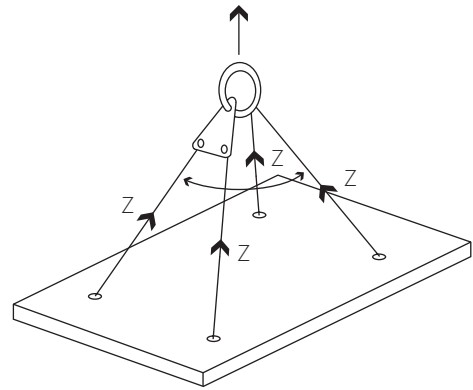

Bei Verwendung eines Stahlträgers wird die Last gleichmäßig auf alle vier Anker verteilt.

When using a cross beam, the load is distributed to all vier anchors.

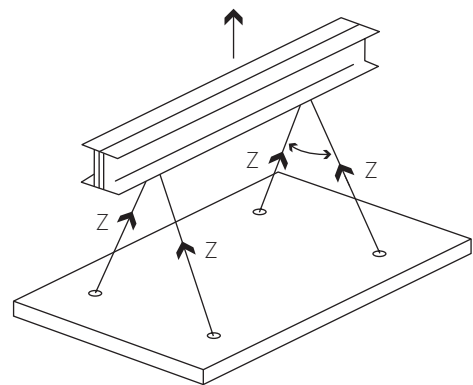

TRANSPORTANKER-SYSTEM FÜR RINGKUPPLUNG

LIFTING SYSTEM FOR RING CLUTCH

Anker in großflächigen Fertigteilen

Anchors for big precast units

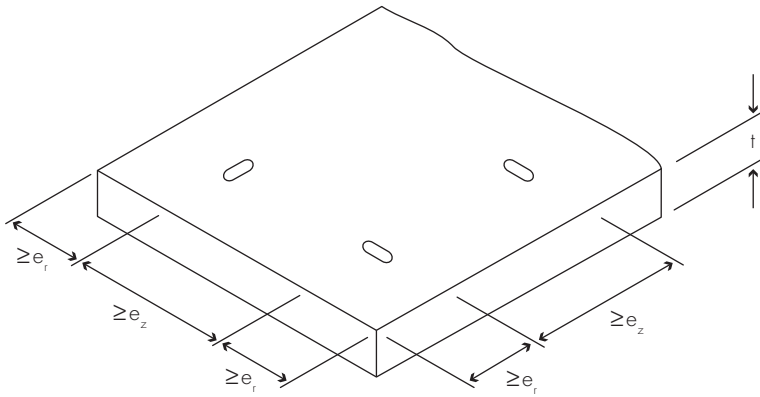

Mindestbauteildicke

- = Ankerlänge
- + Betondeckung
- + Überdeckung Ankerkopf

Minimum thickness of precast unit

- = Anchor length
- + Cover to anchor head
- + Concrete cover to the base of anchor

Anker in dünnwandigen Fertigteilen

Anchors for thin-walled precast units

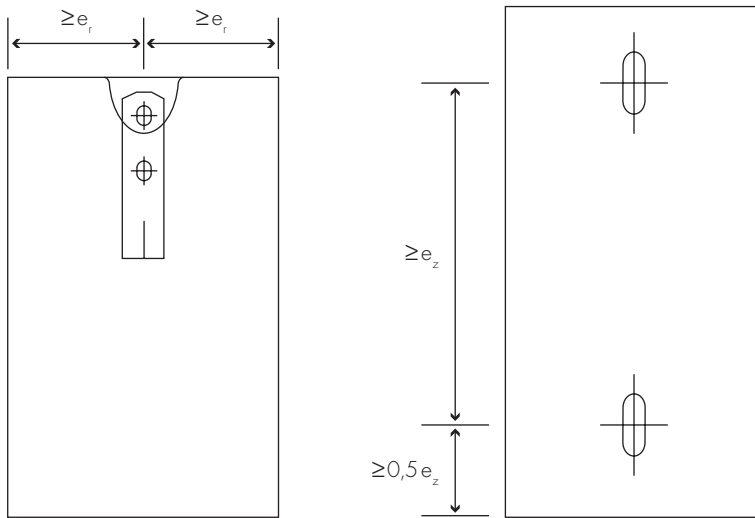

Schrägzugbügel

Stirrup for angled pulls

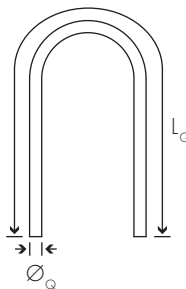
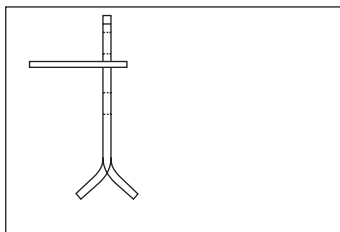

TRANSPORTANKER-SYSTEM FÜR RINGKUPPLUNG

LIFTING SYSTEM FOR RING CLUTCH

Spreizanker Spread anchor

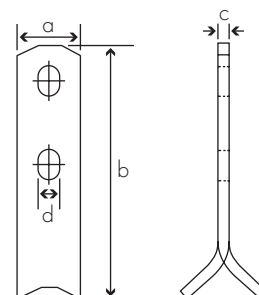

Artikel-Nr. Article No.	Laststufe Loadstep [t]	a [mm]	b [mm]	c [mm]	d [mm]	e _z für/for B15 [mm]	e _r für/for B15 [mm]	Erforderliche Bewehrung Necessary reinforcement	Schrägzugbügel Stirrup for angled pull		
									Ø [mm]	L _Q B15	L _Q B25
6300-00,7-120	0,7	30	120	5	14	385	35	Q 131	6	450	400
6300-01,4-120	1,4	30	120	6	14	385	50	Q 188	6	900	700
6300-01,4-150	1,4	30	150	6	14	560	40	Q 131	6	900	700
6300-02,0-140	2,0	30	140	8	14	455	60	Q 221	8	950	750
6300-02,0-200	2,0	30	200	8	14	560	55	Q 188	8	950	750
6300-02,0-250	2,0	30	250	8	14	735	50	Q 131	8	950	750
6300-02,5-150	2,5	30	150	10	14	525	70	Q 221	8	1200	900
6300-02,5-200	2,5	30	200	10	14	630	65	Q 188	8	1200	900
6300-02,5-250	2,5	30	250	10	14	875	60	Q 131	8	1200	900
6300-03,0-160	3,0	40	160	10	18	560	70	Q 257	10	1150	900
6300-03,0-200	3,0	40	200	10	18	700	65	Q 188	10	1150	900
6300-03,0-250	3,0	40	250	10	18	980	60	Q 131	10	1150	900
6300-04,0-180	4,0	40	180	12	18	630	80	Q 257	10	1500	1200
6300-04,0-240	4,0	40	240	12	18	840	75	Q 188	10	1500	1200
6300-05,0-190	5,0	40	190	15	18	630	90	Q 377	12	1550	1200
6300-05,0-230	5,0	40	230	15	18	840	85	Q 221	12	1550	1200
6300-05,0-400	5,0	40	400	15	18	1400	80	Q 133	12	1550	1200
6300-07,5-250	7,5	60	250	16	27	910	120	Q 377	14	2000	1550
6300-07,5-300	7,5	60	300	16	27	1050	110	Q 221	14	2000	1550
6300-07,5-400	7,5	60	400	16	27	1470	100	Q 188	14	2000	1550
6300-10,0-340	10,0	60	340	20	27	1295	110	Q 221	16	2300	1800
6300-17,0-380	17,0	80	380	20	35	1610	120	Q 257	20	2600	2050
6300-22,0-500	22,0	90	500	28	35	1700	120	Q 257	20	2600	2050
6300-17,0-380	17,0	80	380	20	35	1610	120	Q 257	20	2600	2050

Plattenanker Plate anchor

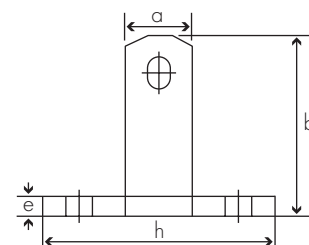

Artikel-Nr. Article No.	Laststufe Loadstep [t]	a [mm]	b [mm]	c [mm]	e x h [mm]	Mind. Achs- & Randabstände Min. spaces between centres		Zulässige Last Permissible load	
						e _r [mm]	e _z [mm]	15 N/mm ² [t]	25 N/mm ² [t]
6200-01,4-055	2,5	30	55	6	8 x 80	115	30	1,12	1,4
6200-02,5-080	2,5	30	80	10	8 x 80	165	30	2,0	2,5
6200-05,0-120	5,0	40	120	15	10 x 100	240	40	4,0	5,0
6200-10,0-160	10,0	60	160	20	12 x 140	330	60	8,0	10,0

TRANSPORTANKER-SYSTEM FÜR RINGKUPPLUNG

LIFTING SYSTEM FOR RING CLUTCH

Aufstellanker einseitig + beidseitig

Erection anchor one-sided + both-sided

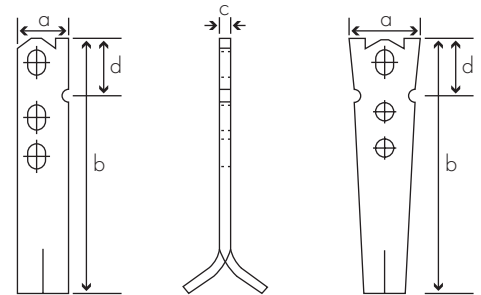

Artikel-Nr. Article No.	Laststufe [t] Loadstep [t]	a [mm]	b [mm]	c [mm]	d [mm]
6700-01,4-200	1,4	40	200	6	42,5
6700-02,5-230	2,5	40	230	10	42,5
6700-04,0-270	4,0	55	270	12	50,5
6700-05,0-300	5,0	55	300	15	50,5
6700-07,5-320	7,5	80	320	15	78,0
6700-10,0-400	10,0	80	400	20	78,0
6700-12,5-500	12,5	115	500	20	88,5
6700-17,0-500	17,0	115	500	25	88,5
6700-22,0-500	22,0	115	500	30	88,5

Artikel-Nr. Article No.	Laststufe [t] Loadstep [t]	a [mm]	b [mm]	c [mm]	d [mm]
6750-01,4-200	1,4	55	200	6	45
6750-02,5-230	2,5	55	230	10	45
6750-04,0-270	4,0	70	270	12	70
6750-05,0-300	5,0	70	300	15	70
6750-07,5-320	7,5	95	320	15	90
6750-10,0-400	10,0	95	400	20	90
6750-12,5-500	12,5	148	500	20	90
6750-17,0-500	17,0	148	500	25	90
6750-22,0-500	22,0	148	500	30	90

Artikel-Nr. Article No.	Laststufe Loadstep [t]	e _z [mm]	Mindestbauteildicke Min. thickness element		Transport	Transport	Aufstellen	Bewehrung Reinforcement BS1 500
			Art. 6700	Art. 6750	↑ 100% [t]	↗ 80% [t]	↘ 50% [t]	
6700/50-01,4-200	1,4	700	90	100	1,4	1,1	0,7	Ø 10 x 700
6700/50-02,5-230	2,5	800	120	120	2,5	2,0	1,3	Ø 12 x 800
6700/50-04,0-270	4,0	950	140	150	4,0	3,2	2,0	Ø 14 x 950
6700/50-05,0-290	5,0	1000	140	160	5,0	4,0	2,5	Ø 16 x 1000
6700/50-07,5-320	7,5	1200	160	175	7,5	6,0	3,8	Ø 20 x 1200
6700/50-10,0-390	10,0	1500	200	200	10,0	8,0	5,0	Ø 20 x 1500
6700/50-12,5-500	12,5	1500	240	240	14,0	11,2	7,0	Ø 25 x 1500
6700/50-17,0-500	17,0	1500	300	300	17,0	13,6	8,5	Ø 25 x 1800
6700/50-22,0-500	22,0	1500	360	360	22,0	17,6	11,0	Ø 25 x 1800

Universalanker

Universal anchor

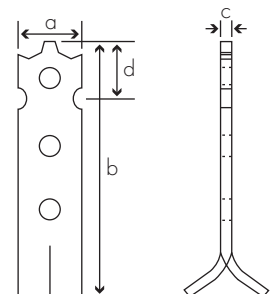

Artikel-Nr. Article No.	Laststufe Loadstep [t]	a [mm]	b [mm]	c [mm]	d [mm]	Mind. Achs- & Randabstände Min. spaces between centres		Zulässige Last bei Betonfestigkeit Permissible load		
						e _z [mm]	e _z [mm]	↑	↗	Aufstellen/Erecting
6200-01,4-055	2,5	30	55	6	25	115	30	1,25 t	1,0 t	0,65 t

TRANSPORTANKER-SYSTEM FÜR RINGKUPPLUNG

LIFTING SYSTEM FOR RING CLUTCH

Zweilochanker Two hole anchor

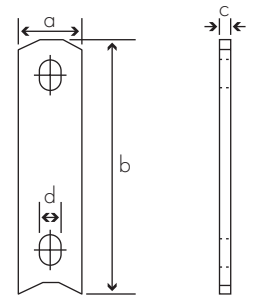

Artikel-Nr. Article No.	Laststufe Loadstep	a [mm]	b [mm]	c [mm]	d [mm]	e _z für/for B15 [mm]	e _r für/for B15 [mm]	Erforderliche Bewehrung Necessary reinforcement	Schrägzugbügel Stirrup for angled pull		
									Ø [mm]	L _Q B15	L _Q B25
6000-00,7-090	0,7	30	90	5	14	500	40	Q131	8	400	400
6000-01,4-090	1,4	30	90	6	14	500	40	Q131	10	650	550
6000-02,0-090	2,0	30	90	8	14	600	50	Q131	12	800	600
6000-02,5-090	2,5	30	90	10	14	600	50	Q131	12	1000	800
6000-03,0-120	3,0	40	120	10	18	650	60	Q131	14	1000	800
6000-04,0-120	4,0	40	120	12	18	700	60	Q131	16	1200	900
6000-05,0-120	5,0	40	120	15	18	750	60	Q131	16	1500	1150
6000-07,5-160	7,5	60	160	15	27	1200	70	Q131	20	1400	1100
6000-10,0-160	10,0	60	160	20	27	1200	80	Q131	25	1850	1450
6000-12,5-240	12,5	80	240	20	35	1500	100	Q131	28	2350	1800
6000-17,0-240	17,0	80	240	20	35	1500	100	Q131	28	2350	1800
6000-22,0-300	22,0	80	300	26	35	1500	120	Q131	2x28	3050	2400

Flachfußanker Flat foot anchor

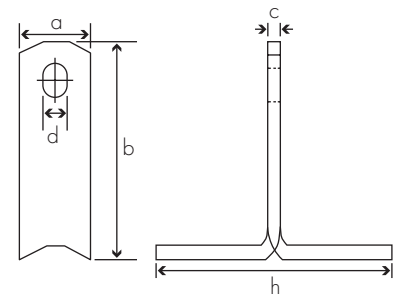

Artikel-Nr. Article No.	Laststufe [t] Loadstep [t]	a [mm]	b [mm]	c [mm]	d [mm]	h [mm]	e _r [mm]	e _z [mm]	Ø [mm]	L _w [mm]
6800-00,7-070	0,7	30	70	5	14	100	130	260	8	200
6800-01,4-075	1,4	30	75	6	14	100	145	290	8	250
6800-02,0-085	2,0	30	85	8	14	100	175	350	8	300
6800-02,5-090	2,5	30	90	10	14	100	200	400	8	300
6800-03,0-100	3,0	40	100	10	18	120	220	440	10	400
6800-04,0-120	4,0	40	120	12	18	120	255	510	12	450
6800-05,0-130	5,0	40	130	15	18	120	290	580	12	500
6800-05,3-140	5,3	60	140	12	27	120	305	610	12	500
6800-07,5-160	7,5	60	160	15	27	120	335	670	14	600
6800-10,0-185	10,0	60	185	20	27	120	390	780	14	600
6800-12,5-200	12,5	80	200	16	35	200	435	870	16	750
6800-17,0-280	17,0	80	280	20	35	200	530	1060	16	900
6800-22,0-300	22,0	80	300	26	35	200	600	1200	20	1100